

Application

Feeding of single sheets or brochures with up to 60 m/min.

Technical Data		Products	
Performance	60 m/min up to 60 cycles/min	Formats	min. 80 x 60 mm max. 300 x 300 mm
Power supply	230 V / 50 Hz, 200 VA	Quality	min. 80 g/m ²
Control	K-Logic	Thickness	0,1 – 5 mm

Standard Properties

- ❶ Magazine loading: 300 mm
 - ❷ Central air gap adjustment: 0,1 up to 5 mm
 - ❸ Exit extension 300 mm
 - ❹ Follow-along, spring-loaded upper belt, openable
 - ❺ K-Logic Steuerung incl. Touchscreen
 - ❻ Individual adjustable stack support
- Feeding width up to 300 mm
 - Single product feeding
optional: counting
 - Missing sheet detector by product run-time monitoring
 - Powerful motor, infinitely adjustable
 - Minimum stack level monitoring in magazine

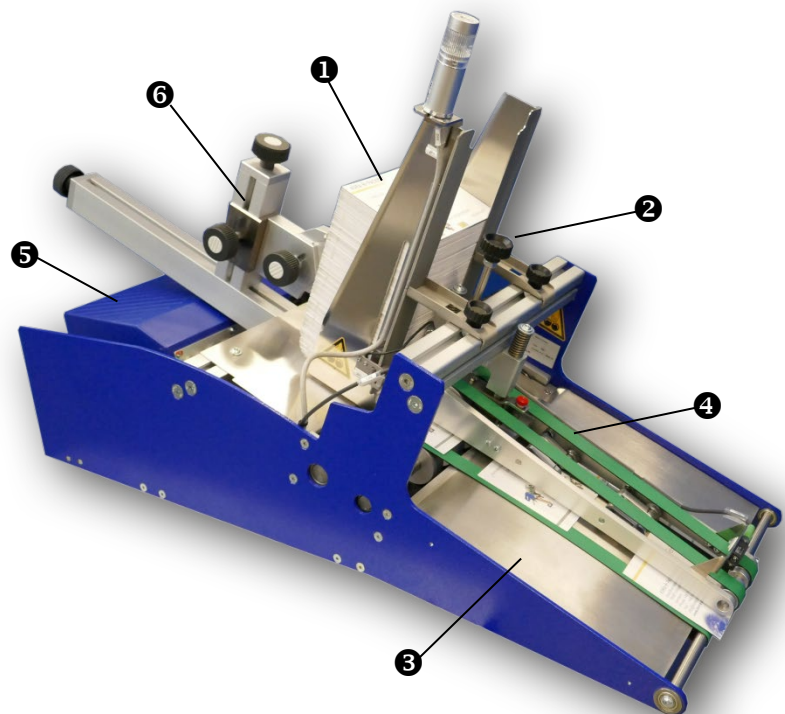

Equipment with signal lamp

Further options see back side

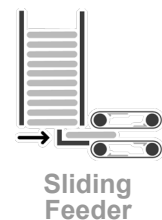
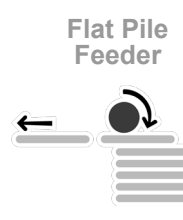
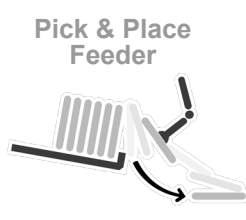
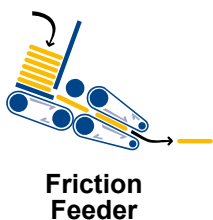

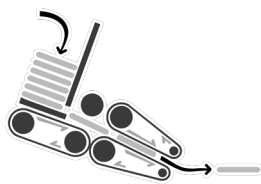

Technical Data (Standard Configuration)

Formats (special formats possible):	min. 80 x 60 mm, max. 300 x 300 mm
Belt speed / Feeding performance (depending on product):	10 - 60 m/min / up to 60 cycles/min (A4, cycled)
Product passage:	min. 0,1 mm, max. 5 mm, paper thickness min. 80 g/m ²
Magazine loading (depending on product):	Standard 300 mm, DIN A4 max. 50 mm usable
Drive:	Servo-Motor, infinitely adjustable
Control:	PLC control; PLC interface 15-pin; protection class IP40; 3.8" touch panel; functions and display for self-diagnosis, fault message, parameter selection, product length setting for missing sheet control, user language selectable (D, E, F standard), etc.
Supply voltage / Power input:	230 V / 50 Hz, 300 W
Dimensions (B x T x H) / Weight:	909 x 359 x 465 mm / approx. 45 kg

Dimensions

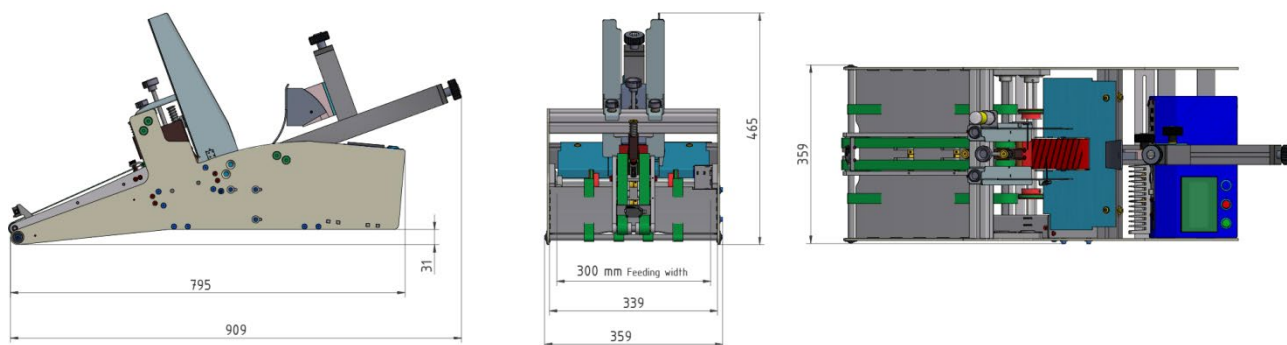

Options

Magazing / Loading

- Magazine height 600 mm
- Autoloader 500 – 3.000 mm (inline or 90°)
- Electric or pneumatic vibrator in stack magazine, switchable

Integration of peripheric devices

- Marking systems (Labeller, Printer)
- Glue systems (hot/cold glue, etc.)
- Monitoring systems (Scanner, camera, etc.)
- Ionization unit

Control / Monitoring

- Signal lamp (1 to 3 colours)
- Level control in Magazine / autoloader

Separation

- Antistatic unit for foil products

Transport - Conveying

- Shingling conveyor
- Stacking tray, adjustable to different formats
- Cleated belt 2-/4-lane
- Vacuum conveyor

Counting & Positioning

- Counting function
- Pulse generator
- Buffer rake for stacking
- Pneumatic down pressing unit

Outfeed Options

- Adjustable lateral guidings in exit extension

Other

- Floorstands: movable, vertically adjustable
- Pre-defined wear part packages
- Start sensor
- Special versions by request

