

Feeder for feeding and glueing machines, for precise positioning of products onto carrier materials

Design and characteristic features:

- Feeding width 300 mm standard
- Single feeding and optional counting
- Feeding at the exact position and/or glueing of the products
- 3-S-System: Exact air gap adjustment of all parameters via digital setting display unit (patent pending)
- Contra-rotating separating roll
- Product run-time monitoring for missing sheet detection
- Product magazine easy accessible for loading
- Min. stack monitoring in the magazine
- Individually adjustable and tiltable stack support
- Infinitely adjustable feeding speed
- Highly dynamic drive via AC servo motor
- Intermediate belt for products smaller than feeding length 60 mm
- Exit extension 300 mm with flat belt, width 20 mm and knife edge for exact feeding
- Upper part of the exit extension is tiltable
- Spring mounted pressure bar with rolls, tiltable with upper part of the exit extension
- Adjustable lateral guides
- Shortened lateral plates, reinforced version
- Encoder included
- Vacuum module for friction belt, with multiejector

Control:

- PLC Control
- Operator guidance and status display via touch screen display (with graphics capability)
- Continuous mode operation selectable
- Function test for self-diagnosis
- Fault message indication by way of signal lamp and display
- Adjustment of the product length for double sheet detection
- Adjustable product stop position
- Operator language selectable in 5 languages
- Electric plug-type connections
- External synchronization of belt speed via incremental encoder

Lettershop version:

- Pneumatic vibrator at stack support
- Adjustable pressure rollers after exit extension
- Start light barrier for external start pulse
- Glue applicator trigger function

Format range (special formats possible):	min. 25 x 60 mm, max. 300 x 335 (L x W)
Speed/ feeding performance (depending on product):	Max. 150 m/min. / up to 1,400 products/min. (continuously) / up to 600 products/min (cycled)
Product passage:	Min. 0, 1 mm, max. 30 mm, paper grade min. 60 g/m ²
Magazine loading (depending on product):	Standard 600 mm, Option 800 mm / 1,000 mm
Drive:	AC servo motors, infinitely adjustable, position accuracy up to +/- 1.5 mm
Control / Display:	PLC control, with touch screen
Supply voltage / Power consumption:	3 x 400 V / N / PE / 50 Hz, 300 W, separate switch cabinet
Compressed-air connection:	6 bar dry, oil-free air, connection 1/4 "
Dimensions (W x D x H) / Weight:	505 x 995 x 944 mm (only feeder, exit extension 300 mm, standard stack height) / about 36 kg, without autoloader, depending on the design

Dimension standard machine, feeding width 300 mm:

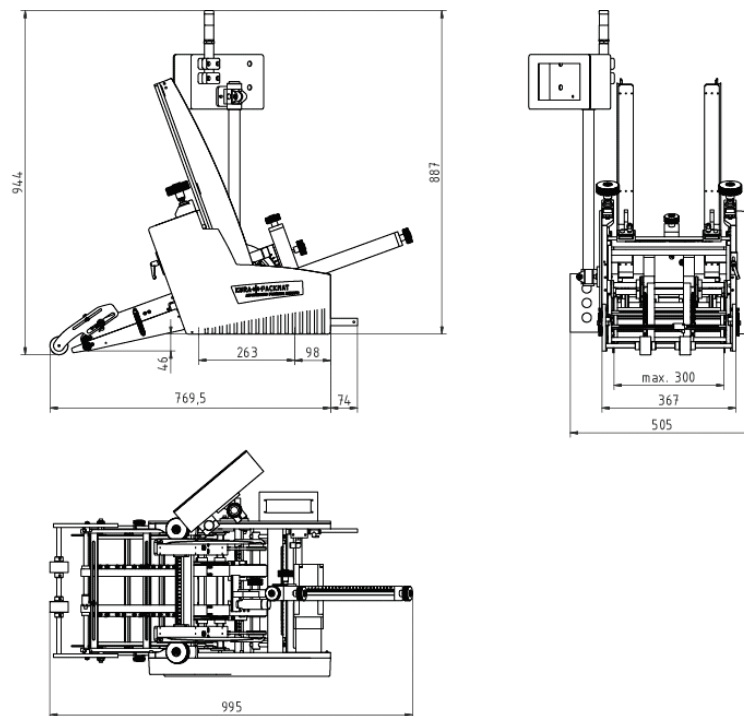

02/2019 Technical modifications reserved

Options:

Exit extension:	Up to 500 mm, inclination up to 90°
Feeding widths:	250 to 500 mm, special formats possible
Support extension:	Up to a maximum of 700 mm , special dimensions upon request
Double sheet detector:	- Mechanical / electrical - Ultrasound sensor
Magazine loading	
Autoloader:	500 mm to 3,000 mm, optionally vertical magazine for autoloader
Level control:	In the stack magazine
Warning lamp:	3 colours
Base:	Movable and vertically adjustable +/- 50 mm, Movable with electrically driven height setting, setting range +/- 200 mm
Higher feeding performance:	220 m/min.

